



## Fixed Mount Linear Imager Bar Code Reader

Using advanced imaging technology, the Gryphon™ I GFS4100 fixed mount bar code reader provides a complete self-contained solution for OEM use into self-service kiosks, price verifiers, ticket readers, document handling, and medical laboratory applications, as well as vending machines and other automated equipment.

Designed for easy integration, the Gryphon I GFS4100 reader provides a simple 'plug-and-play' solution for system designers. Constructed using high-impact resin to withstand repeated cleanings with solvents and disinfectant solutions, the sealed enclosure meets industrial standards against water and particulates to provide dependable and reliable scanning performance.

The Gryphon I GFS4100 OEM module shares the same excellent reading characteristics found in the premium line of Gryphon™ 4100 series of handheld devices. Featuring outstanding near-field reading, a wide angle field-of-view, improved motion tolerance and snappy reading, it also offers integrators excellent performance on

decoding poor or damaged codes. As with all Gryphon readers, the GFS4100 reader offers users additional good-read visual confirmation with Datalogic's patented 'Green Spot' technology.

The Gryphon I GFS4100 reader supports several modes that can be used as a trigger. The module has the ability to automatically sense objects and trigger itself. A continuous scan mode transmits data whenever a bar code passes into its field of view. The reader can be triggered remotely using input from programmable logic controller (PLC) or sensor.

Available in two models, the GFS4150-9 model supports an RS-232 serial interface, or the GFS4170 features a USB interface. The USB version supports both USB-HID for easy integration and keyboard emulation, or USB COM for virtual serial communications.



## Features

- High-speed imaging for fast moving codes
- Read rate: 320 reads/second
- Excellent near-field reading at the scan window
- Supports all common linear (1D) bar codes including GS1 DataBar™
- Reads high resolution bar codes up to 3 mils
- Datalogic's patented Green Spot for good-read feedback
- Integrated good-read beeper
- Automatic sensing or manual trigger options available
- Integrated interface cable
- High-impact resin creates a solvent-tolerant enclosure
- Water and Particulate Sealing Rating: IP54

# Specifications

## DECODING CAPABILITY

1D / LINEAR CODES Autodiscriminates all standard 1D codes including GS1 DataBar™ linear codes

## ELECTRICAL

CURRENT Operating (Typical): 390 mA  
Standby/Idle (Typical): GFS4170: < 2.5 mA  
INPUT VOLTAGE 5 VDC +/- 5%

## ENVIRONMENTAL

AMBIENT LIGHT 0 - 100,000 lux  
DROP RESISTANCE Withstands repeated drops from 0.76 m / 2.50 ft onto a concrete surface  
ESD PROTECTION (AIR DISCHARGE) 16 kV  
HUMIDITY (NON-CONDENSING) 95%  
PARTICULATE AND WATER SEALING IP54  
TEMPERATURE Operating: 0 to 50 °C / 32 to 122 °F  
Storage/Transport: -25 to 50 °C / -13 to 122 °F

## INTERFACES

RS-232; USB

## PHYSICAL CHARACTERISTICS

COLORS AVAILABLE Grey; Other colors and custom logo options are available for minimum quantity purchase.  
DIMENSIONS 3.9 x 5.7 x 5.8 cm / 1.5 x 2.2 x 2.3 in  
WEIGHT 170.0 g / 6.0 oz (including a 2.0 m / 6.6 ft RS-232 cable)

## READING PERFORMANCE

IMAGER SENSOR CCD Solid State  
LIGHT SOURCE Illumination: Dual LED Array 630 - 670 nm  
PRINT CONTRAST RATIO (MINIMUM) 15%  
READ RATE (MAXIMUM) 320 reads/sec.  
READING ANGLE Pitch: +/- 65°; Roll (Tilt): +/- 35°; Skew (Yaw): +/- 65°  
READING INDICATORS Beeper; Datalogic 'Green Spot' Good Read Feedback; Good Read LED  
RESOLUTION (MAXIMUM) 0.076 mm / 3 mils

## READING RANGES

TYPICAL DEPTH OF FIELD Minimum distance determined by symbol length and scan angle. Printing resolution, contrast, and ambient light dependent.  
5 mils: 5.0 to 16.0 cm / 2.0 to 6.3 in  
8 mils: 3.0 to 27.0 cm / 1.2 to 10.6 in  
10 mils: 1.5 to 30.0 cm / 0.6 to 11.8 in  
13 mils: 3.0 to 40.0 cm / 1.2 to 15.7 in  
20 mils: up to 60.0 cm / up to 23.6 in

## SAFETY & REGULATORY

AGENCY APPROVALS The product meets necessary safety and regulatory approvals for its intended use.  
The Quick Reference Guide for this product can be referred to for a complete list of certifications.  
ENVIRONMENTAL COMPLIANCE Complies to China RoHS; Complies to EU RoHS  
LED CLASSIFICATION IEC 60825-1 Class 1 LED Product

## UTILITIES

DATALOGIC ALADDIN™ Datalogic Aladdin configuration program is available for download at no charge.  
OPOS / JAVAPOS JavaPOS Utilities are available for download at no charge.  
OPOS Utilities are available for download at no charge.  
REMOTE HOST DOWNLOAD Lowers service costs and improves operations.

## WARRANTY

18-Month Factory Warranty

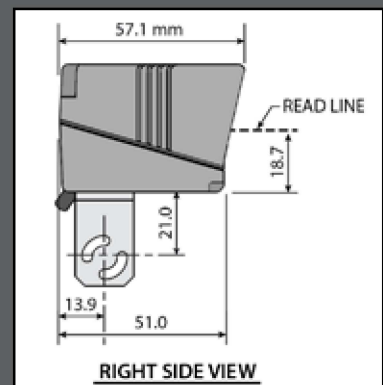
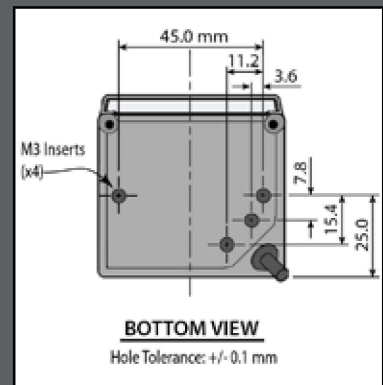
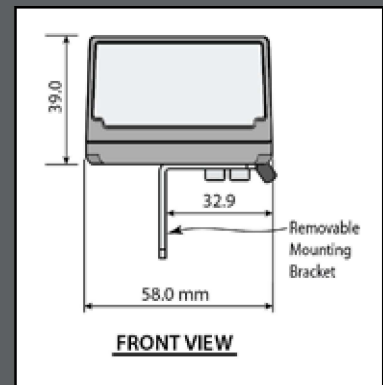

© 2011 Datalogic Scanning Inc.

All rights reserved. • Protected to the fullest extent under U.S. and international laws. Copying, or altering of this document is prohibited without express written consent from Datalogic Scanning, Inc.

Datalogic and the Datalogic logo are registered trademarks of Datalogic S.p.A. in many countries including the U.S.A. and the E.U.

Datalogic Aladdin is a trademark of Datalogic Scanning Group S.r.l.

Gryphon is a trademark of Datalogic Scanning, Inc. • Other brand and product names may be trademarks of their respective owners.

Product specifications are subject to change without notice.

DS-GRYPHONIGFS4100-ENA4 20110411

[www.scanning.datalogic.com](http://www.scanning.datalogic.com)